



Assembly Instructions

Wildwood Bench



*Thank you for choosing **A&L Furniture Co.***

We hope that this piece brings you many years of enjoyment!

For help with assembling your furniture,
or if you have missing hardware, please email us at
help@aandlfurniture.com or call us at 866-896-5747

PARTS (per bench - included)

- Ⓐ Bench Top (1)
- Ⓑ Bench Legs (2)
- Ⓒ Braces (2)

TOOLS NEEDED

7/16" Wrench or Socket
Power Drill

HARDWARE (per bench - included)

- Ⓐ 3½" Bolts (4)
- Ⓑ 2" Lag Screws (4)
- Ⓒ Allen Wrench (1)

STEP 1

Lay the bench top upside down on a clean surface. Place the bench legs on the outside of the 2x2 on the bench top. One side of the leg has a predrilled pilot hole in the center. Make sure this side is turned toward the inside of the bench. Insert the 3½" bolts through the legs & turn into the threaded inserts in the 2x2. Tighten with the Allen wrench. (See photos 1 & 2.)

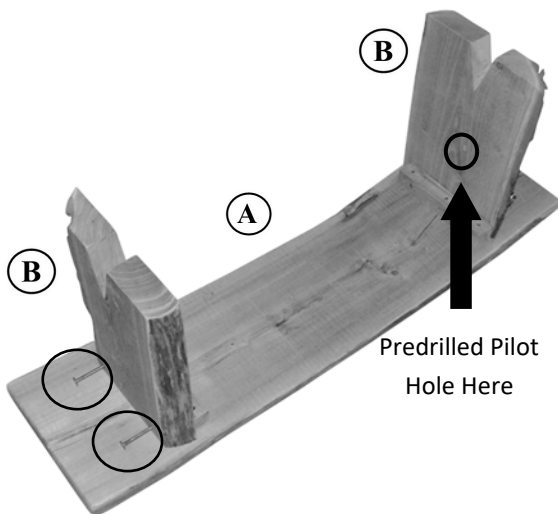

photo 1

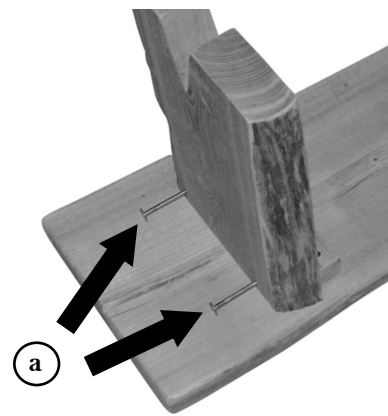

photo 2

STEP 2

Attach the braces to the bench. Align the predrilled hole in one end of the brace with the predrilled pilot hole in the center of the leg & the other hole in the brace with the predrilled pilot hole in the bench top. Fasten with the 2" lag screws. (See photos 3 & 4.) Before fully tightening the lag screws with the 7/16" wrench or socket, set the bench upright. This will prevent it from being uneven when tightened. If you have a 2' bench the braces need to be attached beside each other. (See photo 5.)

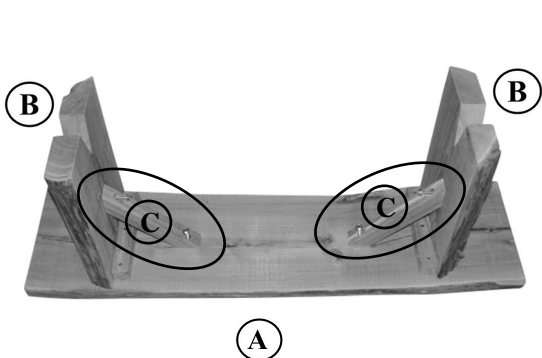

photo 3

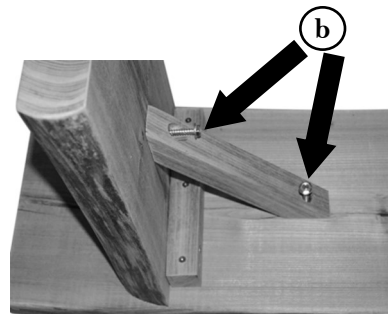

photo 4

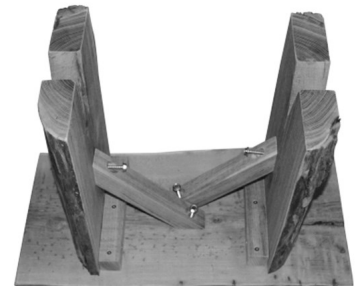

photo 5