



Assembly Instructions

Twin or Full Mission Bunkbed



*Thank you for choosing **A&L Furniture Co.***

We hope that this piece brings you many years of enjoyment!

For help with assembling your furniture,
or if you have missing hardware, please email us at
help@aandlfurniture.com or call us at 866-896-5747

READ THESE INSTRUCTIONS CAREFULLY BEFORE ATTEMPTING TO ASSEMBLE THIS BED.

All VersaLoft Bunkbeds were designed and manufactured with your child's safety as our top priority. Our bunks meet all compliance with ASTM F 1427-07 "Standard Consumer Safety Specification for Bunk Beds" and Code of Federal Regulations (CFR) 1213 "Safety Standards for Entrapment Hazards in Bunk Beds" and (CFR) 1513 "Requirements for Bunk Beds". Safety is a cooperative effort between us as the manufacturer, and you as a guardian. Please read and consider the warnings listed below when choosing a mattress and discussing rules of use with your child.

SAFETY WARNINGS

1. Follow the information on the warnings appearing on the upper bunk end structure and on the carton. Do not remove warning label from bed.
2. Always use the recommended size mattress support, or both, to help prevent the likelihood of entrapment or falls.
3. Surface of mattress must be 5 inches (127mm) below upper edge of guardrails.
4. Do not allow children under 6 years of age to use the upper bunk.
5. Prohibit more than one person on the upper bunk.
6. Periodically, check and insure that the guardrail, ladder, and other components are in their proper position, free from damage, and that all connectors are tight.
7. Do not allow horseplay on or under the bed and prohibit jumping on the bed.
8. Always use the ladder for entering and leaving the upper bunk.
9. Do not use substitute parts. Contact the manufacturer or dealer for replacement parts.
10. Use of a nightlight may provide added safety precaution for a child using the upper bunk.
11. Always use guardrails on both long sides of the upper bunk. If bunk bed will be placed next to a wall, the guardrail that runs the full length of the bed should be placed against the wall to prevent entrapment between the bed and wall.
12. The use of water or sleep flotation mattresses is prohibited.
13. Keep these instructions for future reference.

STRANGULATION HAZARD-Never attach or hang items to any part of the bunk bed that are not designed for use with the bed; for example, but not limited to, hooks, belts, and jump ropes.

SIZE OF MATTRESS AND FOUNDATION

Use only Twin or Full Mattresses with the following specifications on upper and lower bunks:

Twin Mattress: 37-1/2" - 38-1/2" Wide x 74" - 75" Long

Full Mattress: 52-1/2" - 53-1/2" Wide x 74" - 75" Long

Ensure thickness of mattress and foundation combined does not exceed 8" and mattress is at least 5" below the edge of guardrails.

Replacement parts, including additional guardrails, may be obtained from any VersaLoft dealer or directly from us at the address below:

A&L Furniture Co.
112 Four Wheel Drive
Rebersburg, PA 16872
866-896-5747

PARTS (included)

- (A) Headboard (4)
- (B) Post (8)
- (C) Side Rail (4)
- (D) Long Guard Rail (1)
- (E) Short Guard Rail (1)
- (F) Slat Roll (2)
- (G) Ladder (1)



TOOLS NEEDED

Power Drill and/or Screwgun
Flat Head Screw Driver
Hammer

HARDWARE (included)

- (a) 1/4" x 2 3/4" Bolt (16)
- (b) 1/4" x 3 1/2" Bolt (16)
- (c) Dowel Nut (16)
- (d) Allen Wrench (1)
- (e) Square Drive Bit (1)
- (f) 2 1/2" Screw (4)
- (g) 1 3/4" Screw (16)
- (h) 1 1/2" Screw (66)
- (i) Dowel Pin (4)
- (j) Wooden Caps (12) for Full Bed
for Twin Bed (4)



STEP 1

Attach the posts to the headboards using 3 1/2" bolts. (See photos 1 & 2.) Make sure the notches on the posts both turn the same way. Tighten using the Allen wrench.

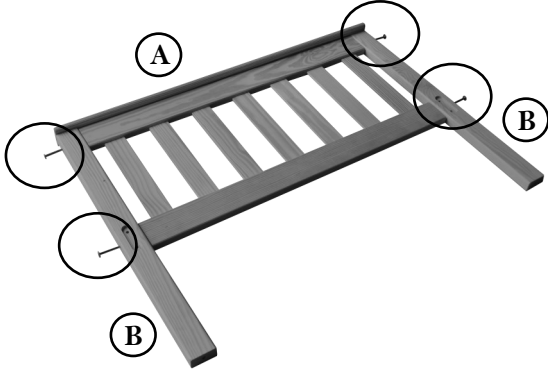

photo 1

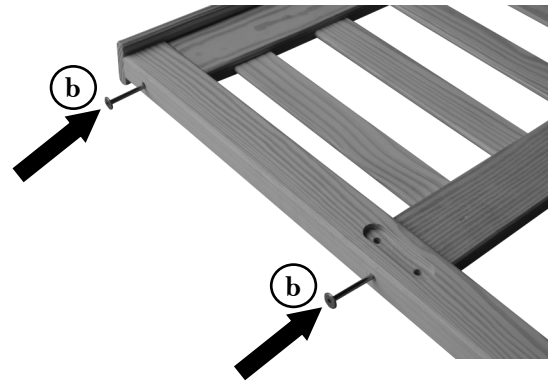

photo 2

STEP 2

You will need someone to help you with this step. Attach the side rails to the headboard/post assemblies. The side rail ends should fit into the notches in the posts. (See photo 3.) Insert a dowel nut into each of the 4 holes on the inside of the side rail. (See photo 4.) Push them in until the hole in the dowel nut lines up with the hole in the post. Now put 2 3/4" bolts through the post into the side rail (see photo 5) and thread them into the dowel nut. Tighten with the Allen wrench. You will need the flat head screw driver to rotate the dowel nuts slightly either way to get the correct alignment.

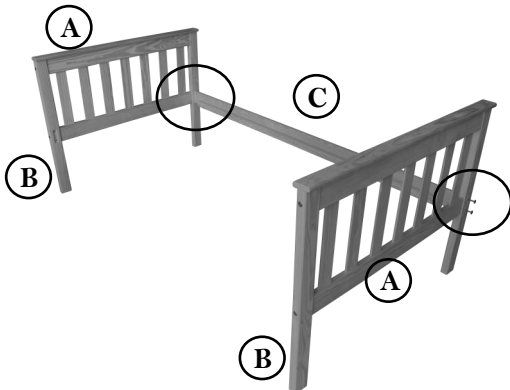

photo 3

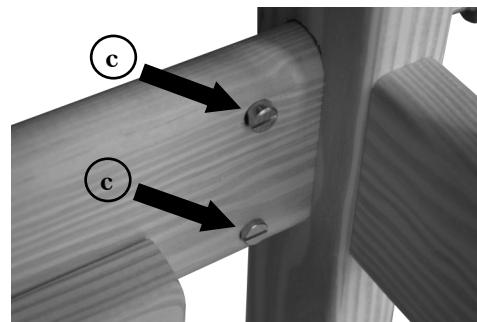

photo 4

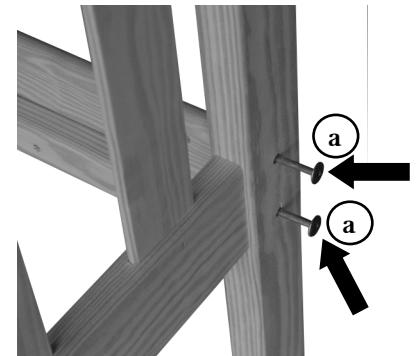

photo 5

STEP 3

Cut the wrap on the slat roll and unroll them onto the bed frame with the string facing up. (See photo 6.) Fasten each slat at both ends to the side rails with 1½" screws (photo 7) keeping the string taut as you go along. Use your power drill or screwgun to drive the screws with the included square drive bit. Note: The screws are self drilling. You shouldn't need to predrill, however, doing so will make them easier to drive. Use drill bit no larger than 7/64".



photo 6

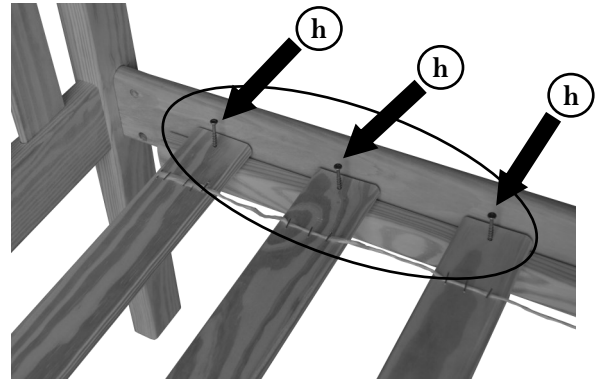

photo 7

STEP 4

Fasten the top of the headboards to the posts using 1½" screws. (See photo 8.) Put wooden caps into the large holes on top of the headboards. (See photo 9.) If you bought a full bunkbed, the headboards will each have 4 of these holes. You may have to tap the caps with the hammer to set them properly.

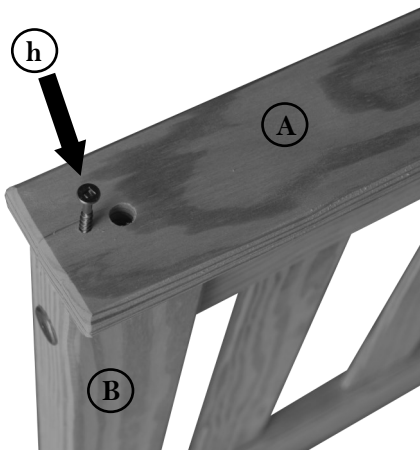

photo 8

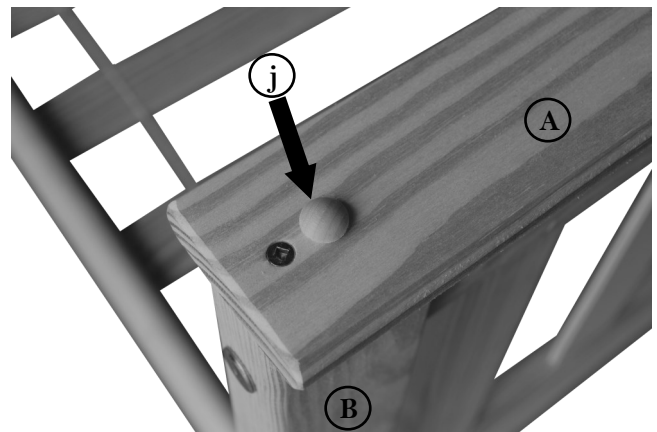

photo 9

STEP 5

Attach the guard rails. (See photos 10 & 11.) You will need to use 1¾" screws on the upright supports on each end of the rails and 1½" screws on the thinner middle supports. Make sure you put the short guard rail in the right place for you to have the ladder where you want it.

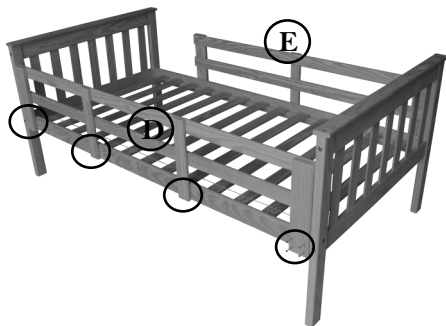

photo 10

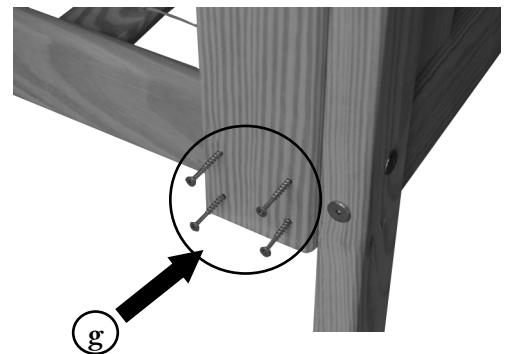

photo 11

STEP 6

Repeat steps 1 through 4 to assemble the second bed except instead of the wooden caps you will need to put the dowel pins in the tops of the headboards. (See photos 12 & 13.) You will probably need the hammer to pound them in. (If you bought a full bunkbed you still need 2 wooden caps in each headboard toward the center.

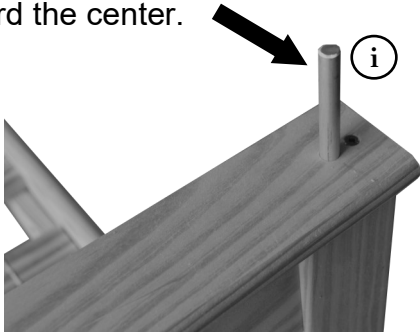

photo 12

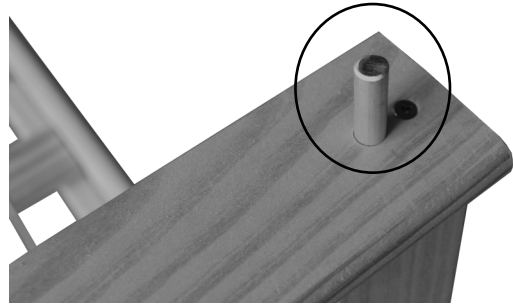

photo 13

STEP 7

Place the bed with the guard rails on the top of the other one. (See photo 14.) The dowel pins should go into the bottoms of the posts but you may have to bend the pins a little one way or the other with the hammer if they do not quite line up with the posts.



photo 14

STEP 8

Attach the ladder. (See photos 15 & 16.) Use 2½" screws and put the ladder in the empty space left by the short guard rail.



photo 15

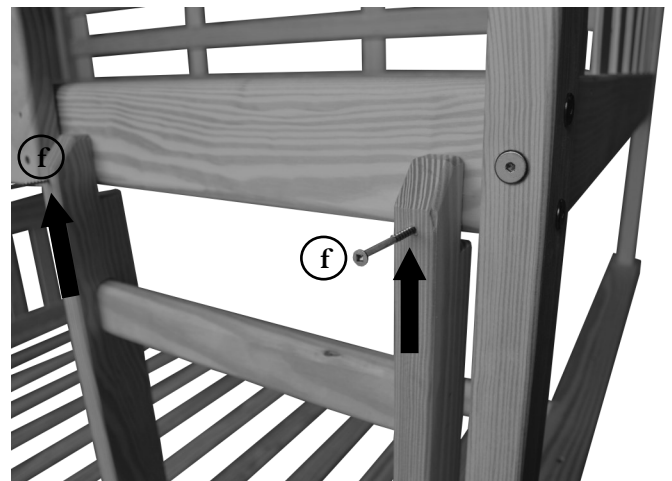

photo 16