



*Assembly Instructions*

## **Twin Over Full Mission Bunkbed**



*Thank you for choosing **A&L Furniture Co.***

*We hope that this piece brings you many years of enjoyment!*

For help with assembling your furniture,  
or if you have missing hardware, please email us at  
[help@aandlfurniture.com](mailto:help@aandlfurniture.com) or call us at 866-896-5747

# READ THESE INSTRUCTIONS CAREFULLY BEFORE ATTEMPTING TO ASSEMBLE THIS BED.

All VersaLoft Bunkbeds were designed and manufactured with your child's safety as our top priority. Our bunks meet all compliance with ASTM F 1427-07 "Standard Consumer Safety Specification for Bunk Beds" and Code of Federal Regulations (CFR) 1213 "Safety Standards for Entrapment Hazards in Bunk Beds" and (CFR) 1513 "Requirements for Bunk Beds". Safety is a cooperative effort between us as the manufacturer, and you as a guardian. Please read and consider the warnings listed below when choosing a mattress and discussing rules of use with your child.

## **SAFETY WARNINGS**

1. Follow the information on the warnings appearing on the upper bunk end structure and on the carton. Do not remove warning label from bed.
2. Always use the recommended size mattress support, or both, to help prevent the likelihood of entrapment or falls.
3. Surface of mattress must be 5 inches (127mm) below upper edge of guardrails.
4. Do not allow children under 6 years of age to use the upper bunk.
5. Prohibit more than one person on the upper bunk.
6. Periodically, check and insure that the guardrail, ladder, and other components are in their proper position, free from damage, and that all connectors are tight.
7. Do not allow horseplay on or under the bed and prohibit jumping on the bed.
8. Always use the ladder for entering and leaving the upper bunk.
9. Do not use substitute parts. Contact the manufacturer or dealer for replacement parts.
10. Use of a nightlight may provide added safety precaution for a child using the upper bunk.
11. Always use guardrails on both long sides of the upper bunk. If bunk bed will be placed next to a wall, the guardrail that runs the full length of the bed should be placed against the wall to prevent entrapment between the bed and wall.
12. The use of water or sleep flotation mattresses is prohibited.
13. Keep these instructions for future reference.

**STRANGULATION HAZARD**-Never attach or hang items to any part of the bunk bed that are not designed for use with the bed; for example, but not limited to, hooks, belts, and jump ropes.

## **SIZE OF MATTRESS AND FOUNDATION**

**Use only Twin or Full Mattresses with the following specifications on upper and lower bunks:**

**Twin Mattress: 37-1/2" - 38-1/2" Wide x 74" - 75" Long**

**Full Mattress: 52-1/2" - 53-1/2" Wide x 74" - 75" Long**

**Ensure thickness of mattress and foundation combined does not exceed 8" and mattress is at least 5" below the edge of guardrails.**

Replacement parts, including additional guardrails, may be obtained from any VersaLoft dealer or directly from us at the address below:

A&L Furniture Co.  
112 Four Wheel Drive  
Rebersburg, PA 16872  
866-896-5747

## PARTS (included)

- Ⓐ Full Headboard (2)
- Ⓑ Twin Headboard (2)
- Ⓒ Post (8)
- Ⓓ Side Rail (4)
- Ⓔ Long Guard Rail (1)
- Ⓕ Short Guard Rail (1)
- Ⓖ Twin Slat Roll (1)
- Ⓗ Full Slat Roll (1)
- Ⓘ Ladder (1)



## TOOLS NEEDED

Power Drill and/or Screwgun  
Flat Head Screw Driver  
Hammer

## HARDWARE (included)

- ⓐ 1/4" x 2 3/4" Bolts (16)
- ⓑ 1/4" x 3 1/2" Bolts (16)
- ⓒ Dowel Nut (16)
- ⓓ Allen Wrench (1)
- ⓔ Square Drive Bit (1)
- ⓕ 2 1/2" Screws (2)
- ⓖ 1 3/4" Screws (16)
- ⓗ 1 1/2" Screws (66)
- ⓓ 1" Screws (2)
- ⓙ Dowel Pins (4)
- ⓚ Wood Caps (8)



## STEP 1

You will need to assemble the full bed first. Attach the posts to the headboards using 3 1/2" bolts. (See photos 1 & 2.) Make sure the notches on the posts both turn the same way. Tighten using the Allen wrench.

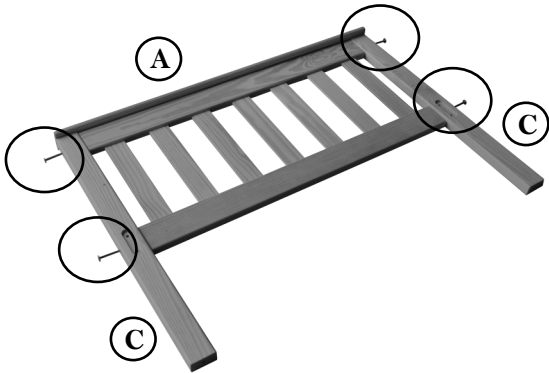

photo 1

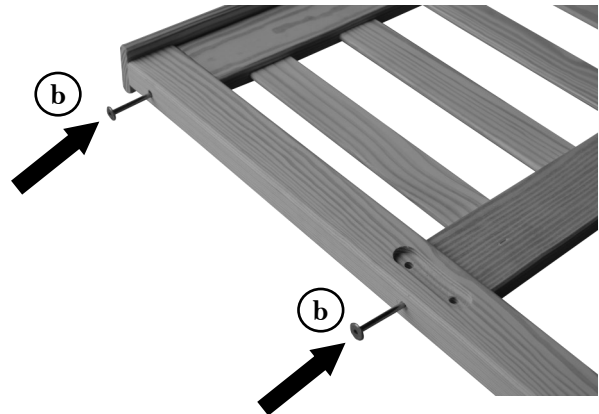

photo 2

## STEP 2

You will need someone to help you with this step. Take 2 headboard/post assemblies and attach the side rails. The side rail ends should fit into the notches in the posts. (See photo 3.) Insert a dowel nut into each of the 4 holes on the inside of the side rail. (See photo 4.) Push them in until the hole in the dowel nut lines up with the hole in the post. Now put the 2 3/4" bolts through the post into the side rail (see photo 5) and thread them into the dowel nut. Tighten with the Allen wrench. You will need the flat head screw driver to rotate the dowel nuts slightly either way to get the correct alignment. Repeat with the second side rail.

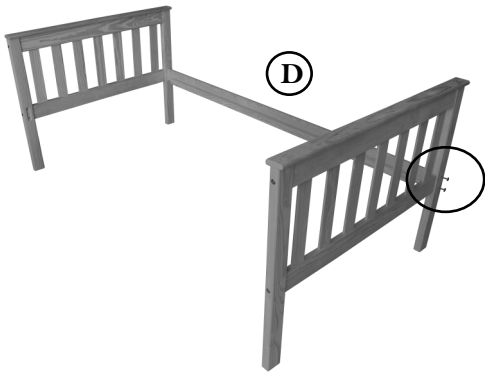

photo 3

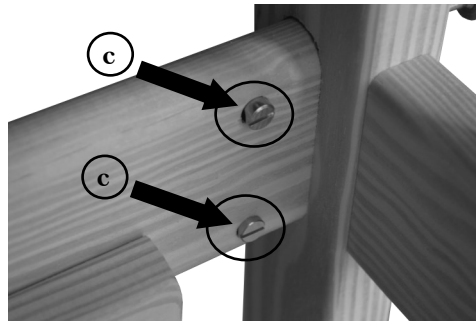

photo 4

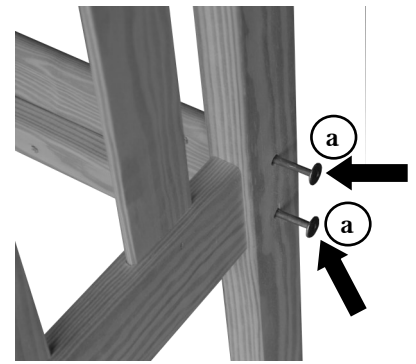

photo 5

### STEP 3

Cut the wrap on the slat roll and unroll them onto the bed frame with the string facing up. (See photo 6.) Fasten each slat at both ends to the side rails with 1½" screws (photo 7) keeping the string taut as you go along. Use your power drill or screwgun to drive the screws with the included square drive bit. Note: The screws are self drilling. You shouldn't need to predrill, however, doing so will make them easier to drive. Use drill bit no larger than  $\frac{7}{64}$ ".



photo 6

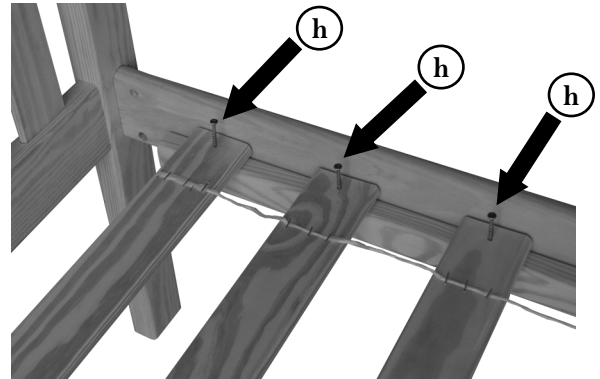

photo 7

### STEP 4

Put 1½" screws through the top of the headboard in to the post (see photo 8) using the square drive bit to drive the screws.

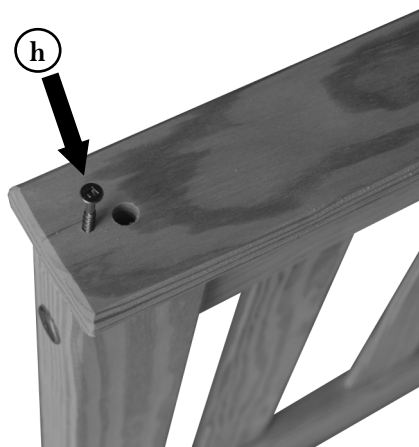

photo 8

## STEP 5

Put the second bed together using Steps 1 through 4. Now put guard rails on the twin bed. (See photo 9.) Use 1¾" screws (see photo 10) for the upright supports on each end and 1½" screws for the thinner middle support. (Be careful to check where you want the ladder before installing the short guard rail.) Now put a wooden cap in each of the 4 holes on top of the twin bed. (See photo 11.) May have to tap with the hammer.



photo 9

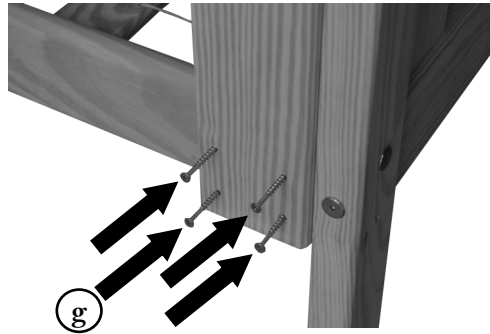

photo 10

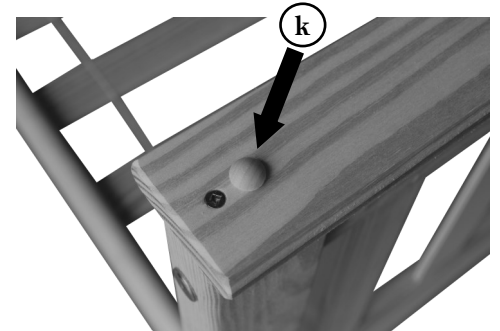

photo 11

## STEP 6

Insert 2 dowel pins into the top of each headboard on the full bed. (See photos 12 & 13.) There are 4 holes in the top of each headboard so be sure to use the 2 holes that align with twin bed posts. The twin bed can be placed on either side of the full bed. Put wooden caps in the remaining holes. May have to tap with the hammer.

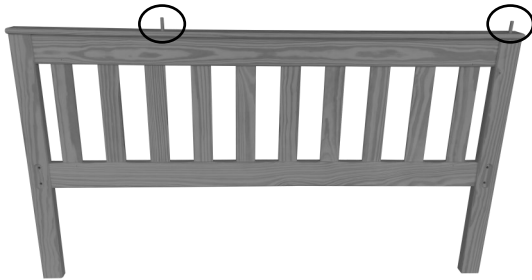

photo 12

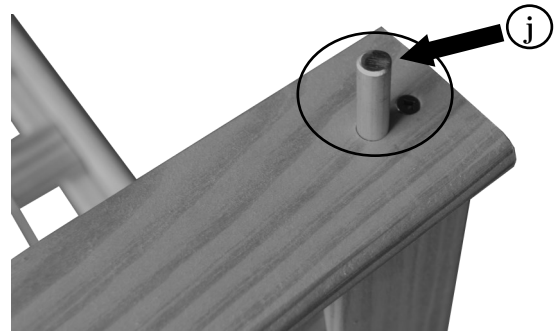

photo 13

## STEP 7

Lift the twin bed on top of the full one, aligning the dowel pins to go into the bottom of the posts - if they do not quite line up you can bend them a little bit either way with the hammer. Attach the ladder as shown. (See photo 14.) Use 2½" screws in the bottom of the ladder (see photo 15) and 1" screws in the metal hooks on top (see photo 16).

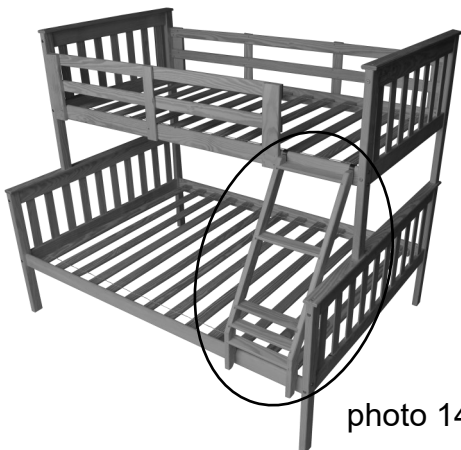

photo 14

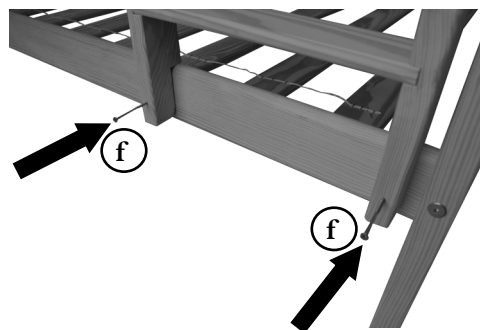

photo 15

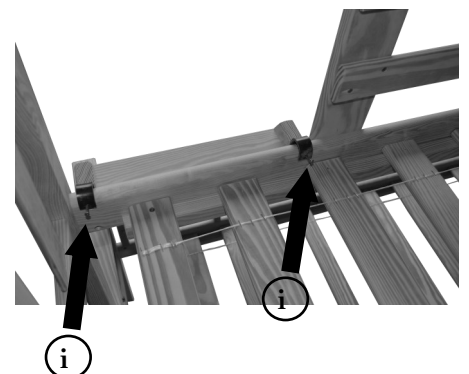

photo 16